

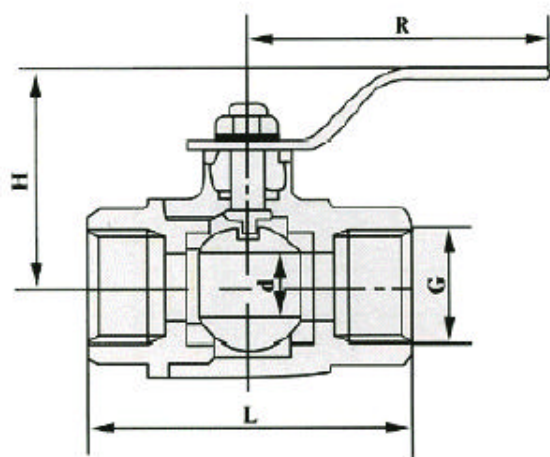

铜内螺纹球阀

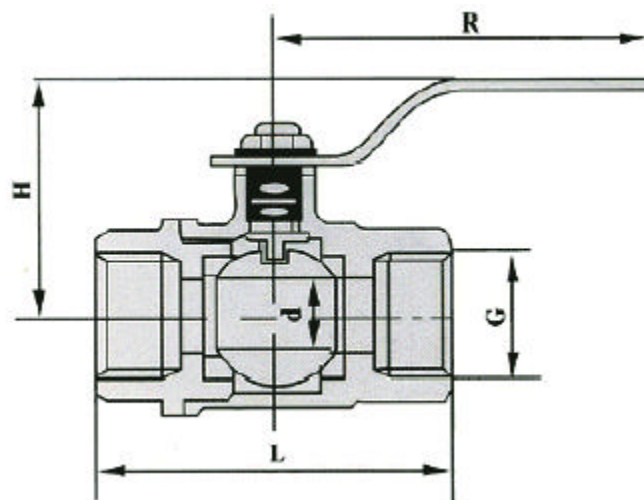

Q11F-25T



Q11F-40T

一、主要性能规范

型号	公称压力 PN(MPa)	试验压力 PS(MPa)		适用温度	适用介质
Q11F-25T	2.5	3.8	2.5	150	水、油、气体
Q11F-40T	4.0	6.0	4.0		
Q21F-25T	2.5	3.8	2.5		
Q21F-16T	1.6	2.4	1.6		





二、主要尺寸及重量

Q11F-25T	管螺纹 G		1/4	3/8	1/2	3/4	1	1 1/4	1 1/2	2
	尺寸 mm	L	53	53	57	70	81	87	95	107
		H	41	41	44	44	51	56	64	69
		R	85	85	100	100	120	120	140	140
		d	9	9	12	16	20	25	30	37
重量 g		204	188	259	401	648	921	1230	1845	
Q11F-40T	管螺纹 G		1/4	3/8	1/2	3/4	1	1 1/4	1 1/2	2
	尺寸 mm	L	53	53	57	70	81	87	95	107
		H	44	44	48	50	55	60	66	72
		R	90	90	105	105	125	125	155	155
		d	9	9	12	16	20	25	30	37
重量 g		220	205	300	445	715	1000	1340	1975	
Q21F-25T	管螺纹 G				1/2		3/4		1	
	尺寸 mm	L		82		100		115		
		H		44		47		51		
		R		100		100		120		
		d		12		16		20		
重量 g				330		520		825		
QK21F-16T	管螺纹 G		尺寸 mm							
	1/2		L	H	R	d				
		44	30	22	9					

三、主要零件材料

零件名称	阀体	球	密封座
材质	黄铜(HPb59-1)锻压	碳钢表面镀铬	增强四氟乙烯